

Panasonic

ideas for life
GepaNet

<http://www.gepanet.com>



Network Color Dome Camera

WV-NF284

Preliminary

MPEG-4 / JPEG



Network Color Dome Camera with MPEG-4 & JPEG Dual Streaming, PoE (Power over Ethernet), 3.6x Variable-Focal Lens

The new Panasonic WV-NF284 is the newest addition to the Panasonic **i-Pro** Series lineup, a compact, stylish network color dome camera with MPEG-4 & JPEG dual streaming.

Select JPEG or MPEG-4 only, and this camera can transmit VGA (640 x 480) images at up to 30 fps. Or using both combines seamless video monitoring of MPEG-4 with high resolution JPEG recording. The 1/4-type progressive scan CCD captures moving subjects with minimal blurring, and multicast (MPEG-4 only) is also supported.

Additional features include the 3.6x variable-focal lens (2.8 - 10mm) that operates in light as low as 1.5 lux (0.15 fc). Power over Ethernet (PoE) IEEE802.3af supplies power and transmits images over the same LAN cable. A high-sensitivity microphone is built-in.

When the camera is connected to an optional **i-Pro** Series Network Disk Recorder, images backed up on the optional SD memory card (during network failure) will be automatically transmitted to the recorder when the network is restored. Additional features include Digital Motion Detection which allows users to program a system to record images automatically.

Reliable performance and easy set-up make the WV-NF284 the ideal network camera for school, transit, warehouse, mall and town security.

KEY FEATURES

- Built-in MPEG-4 and JPEG digital signal output at VGA image size with up to 30 fps.
- MPEG-4/JPEG dual stream output for simultaneous live monitoring and high resolution recording. (See the Frame Rate Chart for details.)
- 3.6x variable-focal lens (2.8 - 10mm).
- Power over Ethernet (PoE) IEEE 802.3af.
- Progressive scan type CCD image sensor.
- Internet Protocol: TCP/IP, UDP/IP, HTTP, RTP, FTP, SMTP, DHCP, DNS, DDNS, NTP and SNMP.
- Image refresh rate: 0.1 fps - 30 fps.
- Bandwidth control: 64 / 128 / 256 / 512 / 1,024 / 2,048 / 4,096 kbps and unlimited.
- Built-in network interface (10Base-T / 100Base-TX) for remote monitoring by PC.
- Sensitivity of 1.5 lux (0.15 fc) at F1.4 with clear dome cover.
- Built-in SD Memory card slot for FTP backup.
- Multi screen display (4 screens x 2 groups).
- Built-in Alarm function for external security devices.
- Built-in digital motion detector.
- Built-in electronic zoom function (1x, 1.5x, 2x, 2.5x and 3x).
- Automatic electronic sensitivity enhancement.
- Built-in microphone (G.726).
- The 3-dimensional hinge (Pan, Tilt and Azimuth) makes adjustments easy.

SYSTEM EXAMPLES

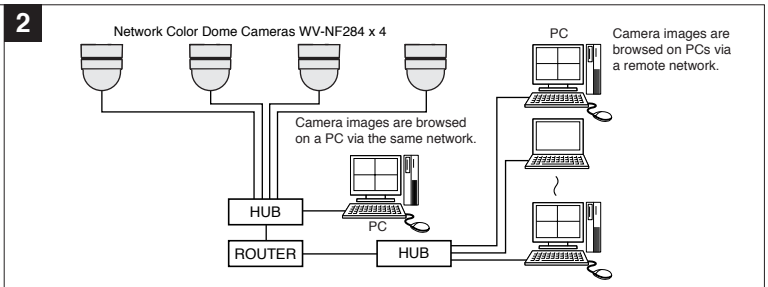
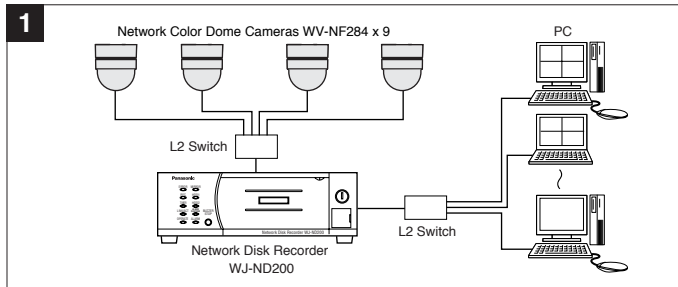

SPECIFICATIONS

Camera Section	
Pick Up Device	1/4-type progressive scan CCD sensor
Effective Pixels	659 (H) x 494 (V)
Scan Mode	Progressive scan
Scanning Area	3.59 (H) x 2.70 (V) mm
Minimum Illumination	1.5 lux (0.15 fc) with clear dome cover (Tentative) 0.19 lux (0.019 fc): at the time of Electronic Sensitivity Up function is 8x. (Tentative)
AGC	Always ON
Electronic Shutter	AUTO
Electronic Sensitivity Up	OFF, AUTO (2x, 4x, 8x, 16x)
White Balance	AUTO / HOLD
Electronic Zoom	1x, 1.5x, 2x, 2.5x, 3x
Title Display	20 alphanumeric characters (Only a browser)
Motion Detector	On/Off Selectable, 1~4 areas, Sensitivity: High/Middle/Low
Back Focus Adjustment	Manual
Lens	
Type	3.6x variable focal lens
Focal Length	2.8 ~ 10 mm
Angular Field of View	H: 20.8° (TELE) ~ 73.5° (WIDE) V: 15.6° (TELE) ~ 54.4° (WIDE)
Aperture Ratio	1 : 1.3 (WIDE)
Min. Object Distance	1.2 m
Analog Output Section	
Signal	NTSC
Monitor Output	VBS 1.0 V [p-p] / 75 Ω, composite signal, ø3.5mm mini jack
Network Section	
Network	10Base-T / 100Base-TX, RJ45 connector for PoE
Image Resolution	JPEG VGA (640 x 480), QVGA (320 x 240) max. 30 fps MPEG-4 VGA (640 x 480), QVGA (320 x 240) max. 30 fps
Image Compression & Transmission	JPEG (Super Fine: 0 / Fine: 1~4 / Normal: 5~8 / Low: 9) selectable, Pull/Push mode MPEG-4 Image Quality (Fine / Normal / Low) selectable, unicast / multicast
Image Refresh Rate	0.1 fps ~ 30 fps (JPEG and MPEG-4 have a limit of a JPEG frame rate at the time of simultaneous movement)
Audio Compression Method	G.726 (ADPCM) 32 kbps/16 kbps Selectable
Traffic Control	64 / 128 / 256 / 512 / 1,024 / 2,048 / 4,096 kbps and unlimited
Internet Protocol	TCP/IP, UDP/IP, HTTP, RTP, FTP, SMTP, DHCP, DNS, DDNS, NTP, SNMP
OS	Windows 2000 Professional SP4, Windows XP Home/Professional SP2
Applicable Browser	Internet Explorer 6.0 SP2 (Windows XP Home/Professional SP2) Internet Explorer 6.0 SP1 (Only Windows 2000 Professional SP4)
FTP Client	Alarm image transfer, FTP periodic transfer
Multi Screen	8 screens (4 screens x 2 group)
Controller I/F	Ethernet
SD Memory Card	64MB, 128MB, 256MB, 512MB, 1GB and 2GB Panasonic SD Memory Card is recommended
External Input Terminals	Alarm input x1/Alarm output x1, AUX output x1
Power Supply	Power Terminal 24 V AC, 60 Hz, 12 V DC Power over Ethernet (IEEE802.3af) 36 ~ 57 V DC (Class2 Powered Device in PoE)
Power Consumption	24 V AC 4.2 W, 12 V DC 350 mA (approx.), PoE 4.2 W (approx.) (Tentative)
Ambient Operating Temperature	-10 °C ~ +50 °C (14 °F ~ 122 °F)
Ambient Operating Humidity	Less than 90 %
Dimensions (D x H)	ø122 mm x 136 mm (ø4-13/16" x 5-3/8")
Weight	Approx. 650 g (1.43 lbs.) (Tentative)

MAJOR OPERATING CONTROLS & TERMINALS

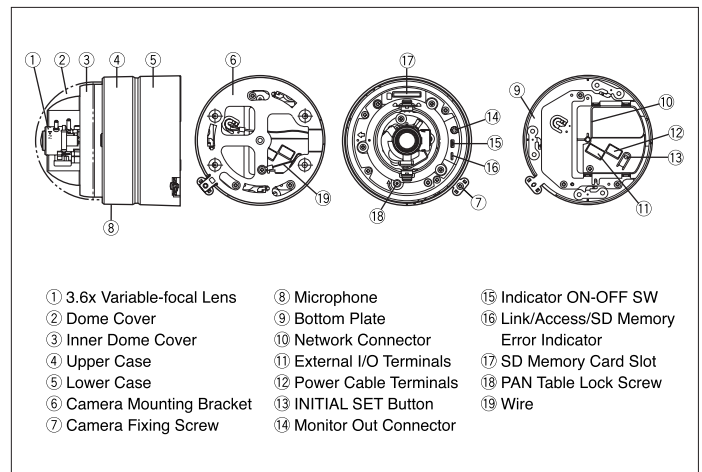

APPEARANCE

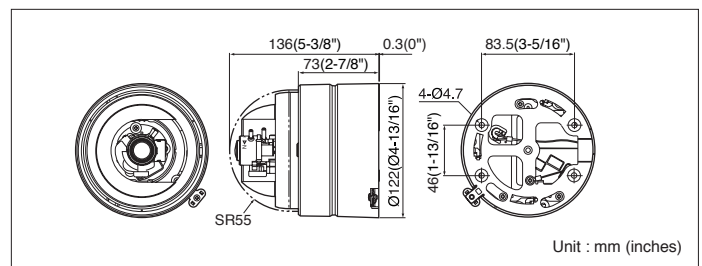

Frame Rate Chart

JPEG		Image Settings									
Image Resolution	Mode	0 Super Fine	1 Fine	2	3	4	5 Normal	6	7	8	9 Low
VGA (640 x 480)	Image Size (KB)	128	96	80	64	56	48	40	32	28	24
	Frame Rate (fps)	10	14	17	21	24	30	30	30	30	30
	Bit Rate (Mbps)	10.2	10.8	10.9	10.8	10.8	11.5	9.6	7.7	6.7	5.8
QVGA (320 x 240)	Image Size (KB)	44	40	36	32	28	24	20	16	14	12
	Frame Rate (fps)	26	28	30	30	30	30	30	30	30	30
	Bit Rate (Mbps)	9.2	9.0	8.6	7.7	6.7	5.8	4.8	3.8	3.4	2.9

MPEG-4		MPEG-4 Bit Rate Settings								
Image Resolution	Mode	4,096 kbps	3,072 kbps	2,048 kbps	1,536 kbps	1,024 kbps	512 kbps	256 kbps	128 kbps	64 kbps
VGA (640 x 480)	Low	30	30	30	25	22	10	5	2	1
	Normal	30	30	30	22	14	8	3	1	0.4
	Fine	27	22	19	13	9	4	1.5	0.5	0.2
QVGA (320 x 240)	Low	30	30	30	30	30	28	24	10	4
	Normal	30	30	30	29	28	24	12	4	1.5
	Fine	30	28	28	28	27	12	5	2	0.5

(above all figures are approximate, actual figures may differ depending on the network under the conditions.)

Trademarks and registered trademarks – Microsoft, and Windows are registered trademarks of Microsoft Corporation in the U.S. and other countries. – SD logo is a trademark.

Important – Safety Precaution: carefully read the operating instructions and installation manual before using this product.

– Panasonic can not be responsible for network performance and/or other manufacturer products that reside on the network.

• All TV pictures/menu are simulated. • Weights and dimensions are approximate. • Specifications are subject to change without notice. • These products may be subject to export control regulations.

Panasonic

Panasonic System Solutions Company
Unit Company of Panasonic Corporation of North America

Security Systems

Website : www.panasonic.com/security

For Customer Support : call 1.877.733.3689

Executive Office : Three Panasonic Way 2H-2, Secaucus, New Jersey 07094

GepaNet

<http://www.gepanet.com>

DISTRIBUTED BY:

GepaNet
88142 Wasserburg
Wiesenstraße 12
Tel +49 8382 9479825
Fax +49 8382 9479826
Mail: info@gepanet.com
WEB: www.gepanet.com

PANASONIC CANADA INC.

5770 Ambler Drive, Mississauga, Ontario, L4W 2T3 Canada (905) 624-5010

PANASONIC PUERTO RICO INC.

DIVISION OF PANASONIC CORPORATION OF NORTH AMERICA

San Gabriel Industrial Park, 65th Infantry Ave. KM. 9.5 Carolina, P.R. 00985 (809) 750-4300

Printed in Japan

WV-JHNF284T(2P-552)